

VME Subrack System 7 U

User Manual



Product Numbers:

20836-715

20836-718

Rev.	Date updated	Change
R1.0	August 22, 2006	Initial Release
R1.1	November 14, 2008	Part no. FCM added

Impressum:

Schroff GmbH

D-75334 Straubenhardt, Germany

The details in this manual have been carefully compiled and checked.

The company cannot accept any liability for errors or misprints. The company reserves the right to amendments of technical specifications due to further development and improvement of products.

Copyright © 2006

All rights and technical modifications reserved.

Table of Contents

1	Safety	1
1.1	Intended Application	1
1.2	Safety Instructions	2
1.3	Safety Symbols used in this document	2
1.4	General Safety Precautions	2
1.5	References and Architecture Specifications	3
2	Product Definition	4
2.1	Mechanical Overview	5
2.2	Subrack	6
2.3	VME Backplane	6
2.4	Power Supply	7
2.4.1	Grounding	7
2.5	Thermals	10
2.6	Fan Control Module (FCM)	11
2.7	Chassis Monitoring Module (CMM) -optional-	12
2.8	Display Module	13
3	Installation	14
3.1	Unpacking	14
3.1.1	Ensuring Proper Airflow	14
3.2	Rack-Mounting	15
3.3	Assembly of additional Backplanes	16
3.4	Basic Functional Check	17
4	Service	18
4.1	Technical support and Return for Service Assistance	18
4.2	Declaration of Conformity	18
4.3	Scope of delivery	19
4.4	Accessories	19
4.5	Spare Parts	19
5	Technical Data	20
6	Mechanical Dimensions	21

1 Safety

1.1 Intended Application

The VME system subrack, described in this manual, is intended as a platform for a microcomputer system based on the VME bus system (VITA 1-1994). The VME system subracks are designed for protection class IP 20 and can be used only in the resp. environments.

For higher protection requirements, a.e. IP 54/55 you must install the system subrack in a protective case.

VME system subracks are not end-products, so there is no valid approval for this unit. In order to enable stand-alone functionality, additional elements are required. An operational system is achieved only by way of appropriate VME boards.

The completion and final testing of the units have been carried out, or at least supervised, by qualified technicians. These instructions are directed exclusively to these qualified technicians i.e. engineers, trained and qualified electricians etc.



Make sure that:

- the assembled unit complies with the safety regulations currently applicable in the country it is going to be used.
- the overall unit complies with all other regulations and specifications at the place and country of use, e.g. interference limits, approval by the telecommunications authorities.

1.2 Safety Instructions

The intended audience of this User's Manual is system integrators and hardware/software engineers.

1.3 Safety Symbols used in this document

	<p>Hazardous voltage! <i>This is the electrical hazard symbol. It indicates that there are dangerous voltages inside the Shelf.</i></p>
	<p>Caution! <i>This is the user caution symbol. It indicates a condition where damage of the equipment or injury of the service personnel could occur. To reduce the risk of damage or injury, follow all steps or procedures as instructed.</i></p>
	<p>Danger of electrostatic discharge! <i>The Shelf contains static sensitive devices. To prevent static damage you must wear an ESD wrist strap.</i></p>

1.4 General Safety Precautions

	<p>Warning! <i>Voltages over 60 VDC can be present in this equipment. This equipment is intended to be accessed, to be installed and maintained by qualified and trained service personnel only. This equipment is designed in accordance with protection class 1! It must therefore be operated only with protective GND/earth connection!</i></p>
---	--

- Service personnel must know the necessary electrical safety, wiring and connection practices for installing this equipment in a telecommunication environment.
- Install this equipment only in compliance with local and national electrical codes.

1.5 References and Architecture Specifications

- User Manual VME Backplanes
Order no.: 73972-103
- Short Form User Manual VME J1/J2 Monolithic Backplanes
Order no.: 73972-128
- User Manual Fan Control Module (FCM)
Order no.: 73972-083

For more information see the catalogue „Electronic Packaging“ and at www.schroff.biz

2 Product Definition

The Schroff VME subrack system consists of:

- A shielded 7 U / 19" subrack with front assembly area for 6 U front boards according to VME Standard (VITA 1-1994)
- A VME (VITA 1-1994) Backplane
- An open frame power supply with wide range input
- Speed controlled fans for cooling the boards
- Fan Control Module (FCM) for fan monitoring/controlling
- Display module
- Mains/line switch

The power supply is assembled on the bottom-hinged rear panel.

3 Axial fans, the Fan Control Module (FCM) and the Display Module are located on a 1 U extractable Fan Tray.

System differences:

The subracks 20836-715/-718 are identical in their construction. The only difference is the depth (355 mm/475 mm).



Variations

The Schroff assembly service can customize your subrack system with:

- *Different Backplane configurations*
- *Drive mounting cassettes*
- *Special power supplies*
- *A Chassis Monitoring Module (CMM)*

More information in the catalogue or at www.schroff.biz

2.1 Mechanical Overview

Figure 1: Mechanical Overview

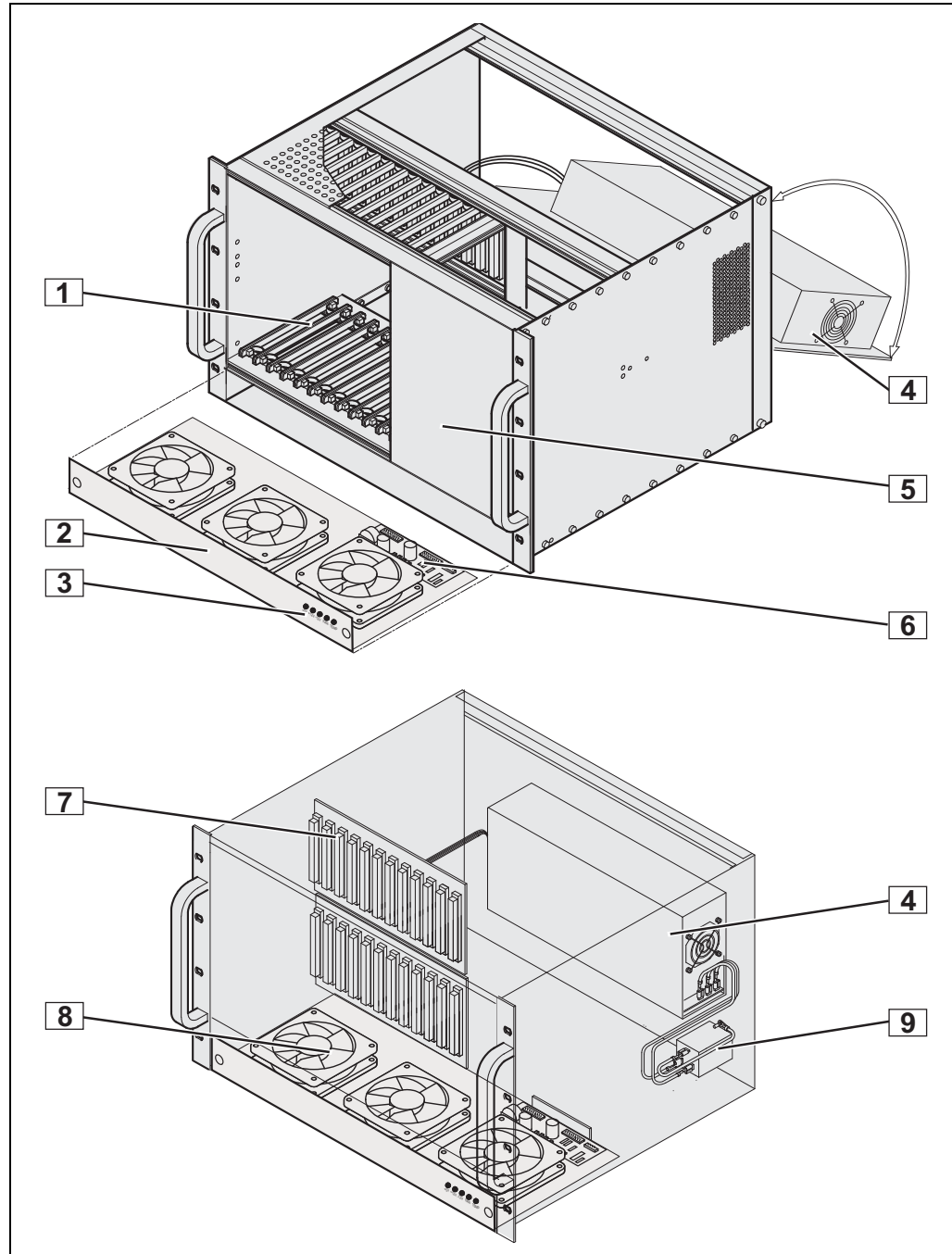

10006823

- | | | | |
|---|----------------------------------|---|--|
| 1 | Front card cage with guide rails | 6 | Fan Control Module (FCM) |
| 2 | Fan Tray | 7 | VME Backplane |
| 3 | Display module | 8 | Axial fans |
| 4 | Power supply | 9 | AC terminal with line filter and Mains/line switch |
| 5 | Front panel 6 U / 36 HP | | |

2.2 Subrack

The 7 U / 19" system based on the Schroff europacPro System with EMC shielding. The front card cage provides space for the installation of 12 VME Boards (6 U, 4 HP, 160 mm deep).

The lower guide rails are fitted with ESD clips.



The front card cage is upgradeable to 21 slots.

2.3 VME Backplane

The 6 U Backplane (J1/J2 Monolithic) is compliant to:

- VITA 1-1994
- VITA 38 Systemmanagement for VME



The subrack systems 20836-715/-718 have a 12-Slot Backplane as standard. You can customize your system with different Backplanes.

For more information see the Backplane's User Manual, Order No.: 73972-103/-128, in the catalogue and at www.schroff.biz



1 Slot = 4 HP = 20,32 mm

2.4 Power Supply

	<p>Hazardous voltage! <i>Parts of the power supply may be exposed with hazardous voltage. Always remove mains/line connector before carry out any assembly work.</i></p>
	<p>Caution! <i>Your system has not been provided with a AC power cable. Purchase a AC power cable that is approved for use in your country. The AC power cable must be rated for the product and for the voltage and current marked on the product's electrical ratings label. The voltage and current rating of the cable should be greater than the ratings marked on the product.</i></p>

The subrack system has a open frame AC power supply with wide range input. The power supply is assembled on the bottom-hinged rear panel. The power input is provided by a AC mains/line module with IEC 320-C14 connector, integrated mains/line fuses, line filter and a mains/line switch.

The maximum fuse value is 8 A.

	<p>Warning! <i>The fuse value has been determined in factory for the maximum power delivered by the power supply. The fuse value must be changed to the actual current of the complete equipped system.</i></p>
---	--

2.4.1 Grounding

	<p>Caution! <i>The unit is designed in accordance with protection class 1! It must therefore be operated with protective earth/GND connection. Use only a three conductor AC power cable with a protective earth conductor that meets the IEC safety standards!</i></p>
---	--

There is a 6,3 mm faston connector at the right side panel. This connector is only for equipotential bonding. Grounding is achieved through the protective earth conductor of the power cable!

Figure 2: Power Supply

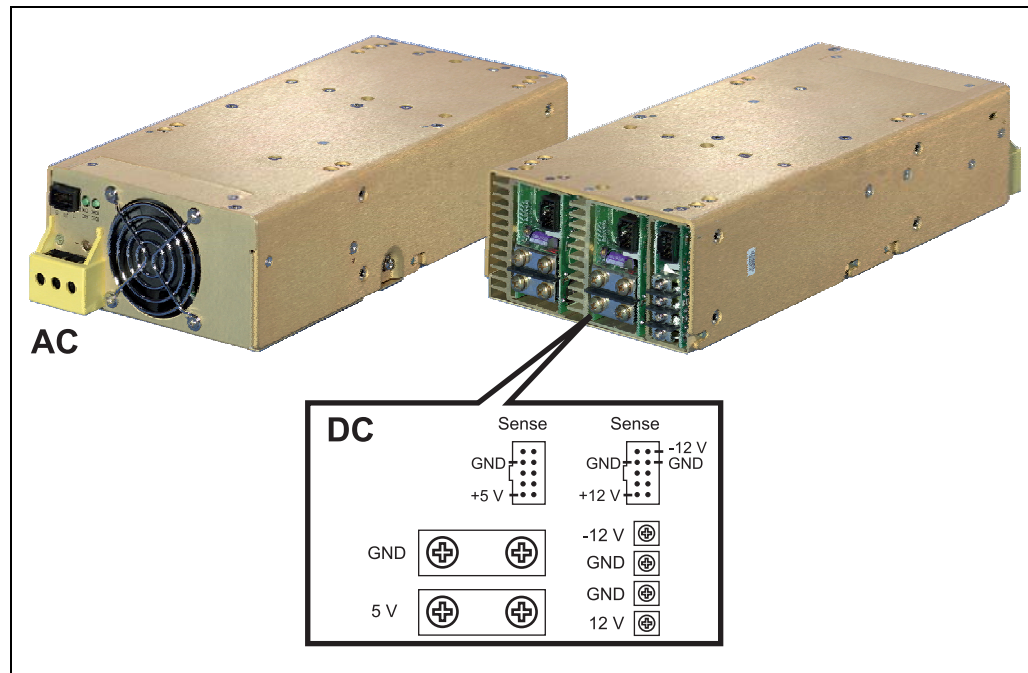

10006819

Table 1: Data AC Power Supply

	Power supply MP4
Input voltage nominal	100 - 240 VAC
Mains Frequency	50 / 60 / 400 Hz
Output (max.)	444 W (400 W if U < 200 VAC)
Output voltages	5.0 V - 60 A 12.0 V - 10 A -12.0 V - 4 A
Ripple	< 1 %
Dynamic response	< 2 % or 100 mV with 25 % load step
Recovery time to within 1%	< 300 µsec
Overvoltage protection	for all voltages 110 – 120 % U > 5 V or 122 – 134 % U < 5 V
Overcurrent protection	105 – 120 % of rated output current
Hold-up time	>= 20 ms

Figure 3: Block Diagram

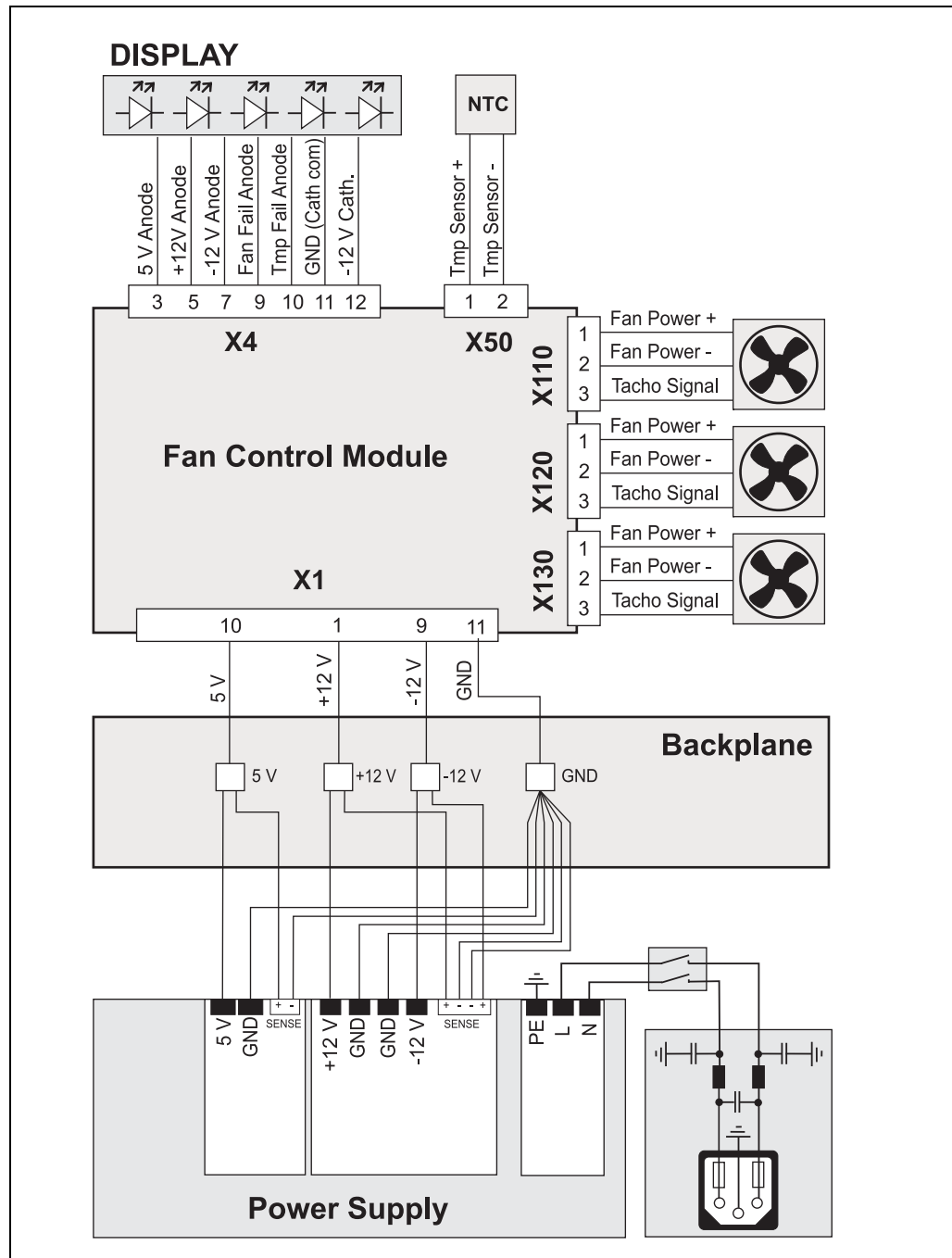

10006820

2.5 Thermals

The front boards are cooled by forced air convection through 3 speed controlled 24 VDC axial fans (each fan 170 m³/h (100 cfm))

The fans are assembled with the Fan Control Module (FCM) on a front-pluggable Fan Tray.

The air enters the subrack at the bottom panel into the Fan Tray and passes across the hot components on the Front Boards. Heat is carried away by forced convection. The air exits the Subrack at the top.

The fan speed is controlled by the Fan Control Module (FCM) depending on the exhaust temperature. The average temperature increase at full load is 6 K.



Caution!

To maintain proper airflow, all open slots must be covered with filler panels. The filler panel should include an airflow baffle that extends to backplane.

Figure 4: Airflow

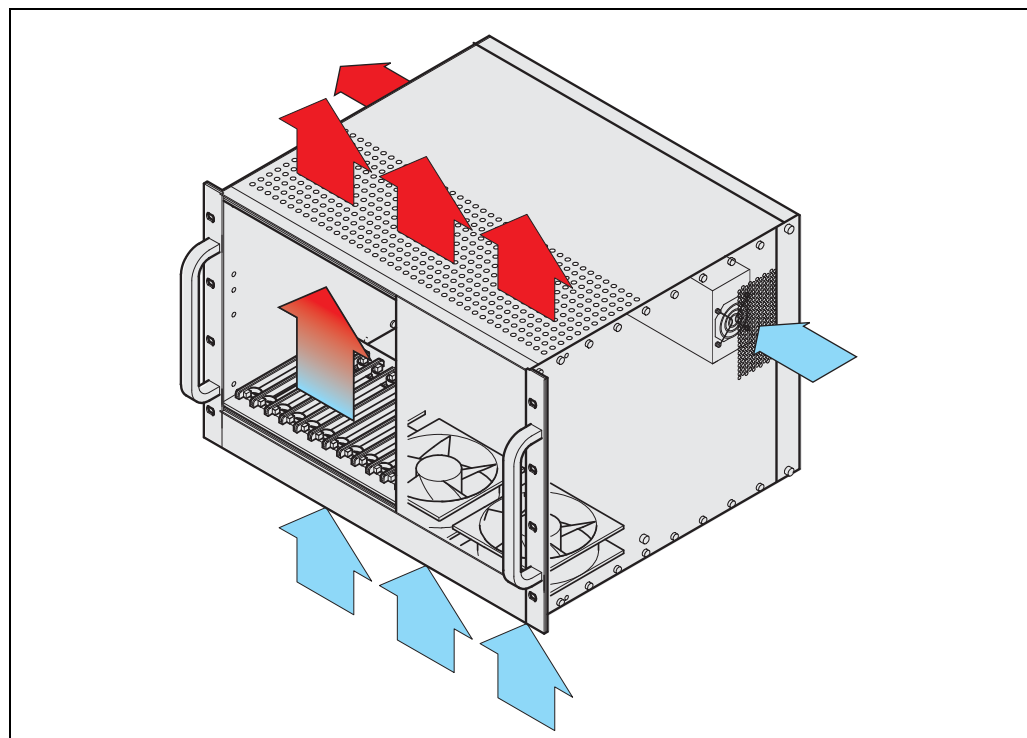

10006824

2.6 Fan Control Module (FCM)

The Fan Control Module (FCM):

- Monitors and controls up to four fans
- Monitors the signals from up to four temperature sensors
- Controls the Display Module
- Speed up the fans in case of a failure of one fan
- Is able to communicate with the optional Chassis Monitoring Module (CMM)

Up to four NTC temperature sensors can be connected to the FCM. The highest temperature level is the reference for the fan speed. If one or more sensors exceed 60° C the output for the temperature fail LED and a digital output are activated. Since the fan speed is temperature controlled by the FCM, the fans rotate with the lowest speed possible. Lower speeds reduce acoustic noise and increase the longevity of the fans.

The FCM also controls a Display Module. 3 green LEDs signal the 3 VME voltages, two red LEDs signal over-temperature and fan fail events.

Figure 5: Diagram fan speed/temperature

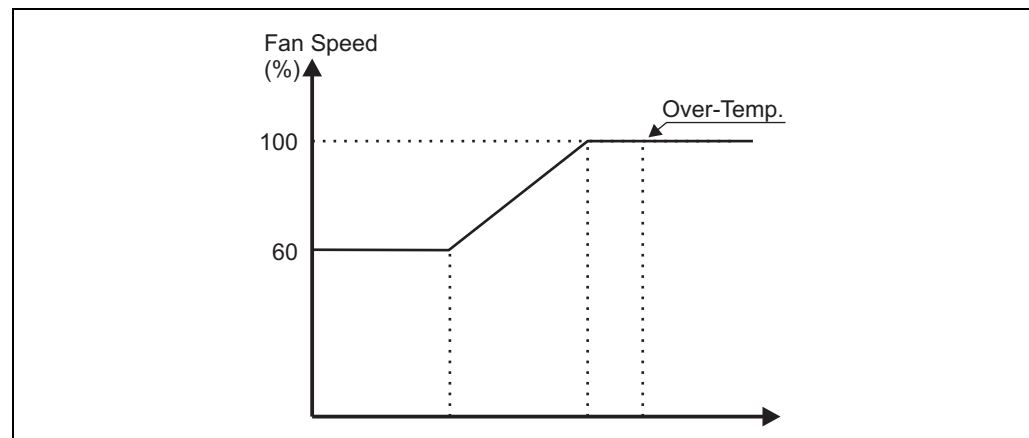

10006807

For more information see the FCM's User Manual, Order No.: 73972-083 and at www.schroff.biz

2.7 Chassis Monitoring Module (CMM) -optional-

The Chassis Monitoring Module (CMM)

- monitors the three VME voltages
- can monitor two additional voltages with a range of $\pm 24 V_{DC}$
- can monitor up to seven NTC temperature sensors
- can communicate with the Fan Control Module (FCM)
- provides 16 digital inputs
- provides 10 digital outputs

The CMM is an optional assembly and not included with the subrack by default. The CMM is a pluggable unit in the 3 U euroboard format with a 3 U/1 HP front panel and can be assembled at the front or rear side.

The CMM allows communication and remote monitoring via RS-232 or Ethernet interface. The front panel provides a RJ45 connector (Ethernet) and a D-Sub9 connector (RS-232).

A user interface via HTML page is available.

The CMM can monitor the 3 VME voltages and two additional voltages (up to $\pm 24 V_{DC}$). The error status can be displayed by LEDs, through the RS-232 serial interface or via ethernet as a HTML page.

Up to 7 NTC temperature sensors can be connected to the CMM. Two alarm thresholds between 20° C and 70° C can be set.

The CMM provides 16 digital inputs and 10 digital outputs for custom specific applications. Four digital outputs are open collector outputs, isolated by opto-couplers, six digital outputs are TTL-compatible non-isolated.

The CMM is connected to the FCM. The temperature values and the fan speeds are transferred to the CMM.

For more information see the CMM's User Manual, Order No.: 73972-084 and at www.schroff.biz

2.8 Display Module

Figure 6: Display Module

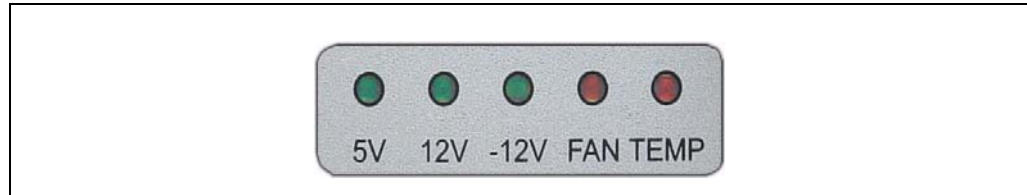

10006821

The Display Module is located at the lower front side of the subrack. 3 green LEDs signal the 3 VME voltages, two red LEDs signal over-temperature and fan fail events.

The Display Module is controlled by the FCM.



When a CMM is present, the Display Module is controlled by the CMM.

3 Installation

3.1 Unpacking



Caution!

When opening the shipping carton, use caution to avoid damaging the system.

Consider the following when unpacking and storing the system:

- Leave the system packed until it is needed for immediate installation.
- After unpacking the system, save and store the packaging material in case the system must be returned.

If the packaging is damaged and possible system damage is present, report to the shipper and analyze the damage.

3.1.1 Ensuring Proper Airflow

- Install the system in an open rack whenever possible. If installation in an enclosed rack is unavoidable, ensure that the rack has adequate ventilation.
- Maintain ambient airflow to ensure normal operation. If the airflow is blocked or restricted, or if the intake air is too warm, an over temperature condition can occur.
- Ensure that cables from other equipment do not obstruct the airflow through the systems.
- Use filler panels to cover all empty chassis slots. The filler panel prevents fan air from escaping out of the front of an open slot.



Caution!

To maintain proper airflow, all open slots must be covered with filler panels. The filler panel should include an airflow baffle that extends to backplane.

3.2 Rack-Mounting

	<p>Warning! <i>Do NOT move the a full equipped system by yourself. Due to the weight at least two persons are needed to accomplish this task</i></p>
---	---

	<p>Warning! <i>Do NOT stack the system on top of any other equipment. If the system falls, it can cause severe bodily injury and damage the equipment.</i></p>
---	---

This subrack system can be installed in 19" equipment racks. The rack must be accessible from the front and rear for equipment installation.

Mounting brackets and a rack mount kit come with the system. Allow sufficient clearance around the rack for system maintenance.

Mounting Instructions:

- Ensure that the rack is constructed to support the weight and dimensions of the Shelf.
- Install any stabilizers that came with your equipment rack before mounting or servicing the system in the rack.
- Load the rack from the bottom to the top, with the heaviest system at the bottom, avoid uneven mechanical loading of the rack.
- We recommend to use also chassis support brackets.

3.3 Assembly of additional Backplanes

With the subrack systems 20836-715/-718 you can assemble an additional Backplane.

Obey the following instructions:

- 1 Disconnect the System from the line/mains power supply.
- 2 Remove the front panel.
- 3 Mount the guide rails.
- 4 Remove the back panel.
Note: Open the back panel to an angle of 135°. At this angle you can separate the hinges and remove the back panel completely.
- 5 Attach the new Backplane with two M2.5 screws and isolating washers at the top and the bottom, but do not tighten the screws.
- 6 To align the Backplane, insert a VME board in the outer guiderails at the left and the right.
- 7 Attach the Backplane using M2.5 screws and isolating washers.
Note: Use at least every second mounting hole at the top and the bottom.
- 8 Connect the Backplane to the system power.
- 9 Attach the rear panel.
- 10 Power-up the systems without the VME boards and check all VME voltages at the backplane connectors.
Note: For instructions see Kapitel 3.4, "Basic Functional Check".



For more information and further assembly instruction see the Backplanes User manual.

3.4 Basic Functional Check



Warning!

Voltages over 60 VDC can be present in this equipment. This equipment is intended to be accessed, to be installed and maintained by qualified and trained service personnel only.

*This equipment is designed in accordance with protection class 1!
It must therefore be operated only with protective GND/earth connection!*

Before starting the system with VME boards the following tests have to be done:

- Ensure that the unit does not get damaged during transport.
- Check the Protective Earth (PE) resistance, should be < 0,1 Ohm.
- Switch on the system and check all VME voltages on the Backplane connectors before you plug in the VME boards.
Note: The +12 V output requires 10% minimum load, i.e. a resistor 12 Ohm / 12 W.
- Plug in the VME boards.
- Cover all open Slots with filler panels.
- Tighten the rear panel mounting screws.
- Power-on the system and determine the actual current consumption.
- Replace the mains fuses suitable to the actual current.



The fuse value has been determined in factory for the maximum power delivered by the power supply. The fuse value must be adjusted to the actual current consumption of the completed system.

Maximum value is 8 A slow.

Figure 7: Mains Fuses

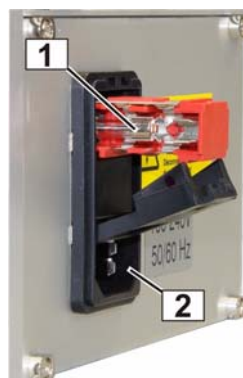

10006815

1 Fuse

2 Power Socket

4 Service

4.1 Technical support and Return for Service Assistance

For all product returns and support issues, please contact your Schroff sales distributor or www.schroff.biz.

We recommend that you save the packing material. Shipping without the original packing material might void the warranty.

4.2 Declaration of Conformity

Microcomputer packaging systems are not complete units which can be delivered directly to the end user, other items need to be fitted.

As it is defined in the EMC standard, it is not designated as a device. A CE symbol is therefore not required. However, the systems comply with all requirements. Each individual component complies to the EMC standard 89/336/EWG and to the low frequency standard 73/23/EWG.

These systems are generally equipped with power supplies having the CE symbol (EN 60950, EN 61000-6-3, EN 61000-6-2).

The choice of the mains filter is carried out by considering the limited values' curve, according to EN 55022 class B.

To warrant the interference immunity according to EN 61000-6-2, the shielding attenuation is measured in the frequency range from 30 MHz to 1000 MHz according to VG 95 373, Part 15.

The systems are developed and manufactured according to EN 60950. High-voltage tests, protective earth tests and functions tests are done on each series system.

4.3 Scope of delivery

Quantity	Description
1	19" subrack, shielded, with perforated top and base covers and front handles. (front handles: RAL 7016; 19"-brackets, top and base covers: RAL 9006)
1	VME Backplane J1/J2 monolithic (VITA 1-1994); 12-Slot 6 U
1	Front assembly area for max. 12 Boards 6 U 160mm deep. Guide rails incl. ESD-Clips (ESD-Clips assembled at front bottom)
1	AC mains/line module with IEC 320-C14 connector, mains fuses mains/line switch and line filter
1	Open Frame power supply 444 W with wide range input 100 VAC to 240 VAC (with 3 voltages: 5 V / 60 A; 12 V / 10 A, -12 V / 4 A)
1	Complete AC/DC wiring
1	Display module
3	Speed controlled fans, assembled on extractable Fan Tray
1	FCM-Module for fan monitoring and controlling
1	Front plate 6 U, 36 U assembled at the right front side

4.4 Accessories

Parts-No.	Description
23207-022	Chassis Monitoring Module (CMM)
20848-7xx	Filler panel with EMC front plate for empty Slots, dimensions see catalogue
34562-8xx	Filler panel for empty Slots, dimensions see catalogue
24579-03x	Printed Circuit Board covers, dimensions see catalogue
20836-750	19" case for 7 U system (Only for 20836-715)

4.5 Spare Parts

Parts-No.	Description
23207-028	Fan Control Module (FCM)

5 Technical Data

Table 2: Technical Data

Dimensions	
Height	310.5 mm (7 U)
Width	483 mm (19")
Depth (20836-715)	355 mm
Depth (20836-718)	475 mm
Weight	
(20836-715)	17 Kg
(20836-718)	20 kg
Power supply	
Input voltage	100 VAC to 240 VAC
Mains frequency	50 / 60 / 400 Hz
Power consumption	up to 444 W
Cooling	
3 x 24 VDC Fans	Each 170 m ³ /h (100 cfm)
Ambient Temperature	
Operating	0 °C to +40 °C
Storage	-40 °C to +85 °C
Humidity	
permissible Humidity	30 % to 80 %, non condensing
EMC, the system meets the requirements for:	
Emitted Interference	EN 55022
Interference Resistance	EN 55024
Safety	
Test voltage according to EN 60950	Input - Output: 4,3 kVDC Input- PE: 2,2 kVDC Output - PE: 0,7 kVDC Output - Output: 0,7 kVDC
Shock and Vibration:	EN 60068-2-6 and EN 60068-2-27
Electromagnetic Shielding	
Shielding attenuation	typ. 40 dB at 1 GHz if shielded front panels are used.

6 Mechanical Dimensions

Figure 8: Mechanical Dimensions

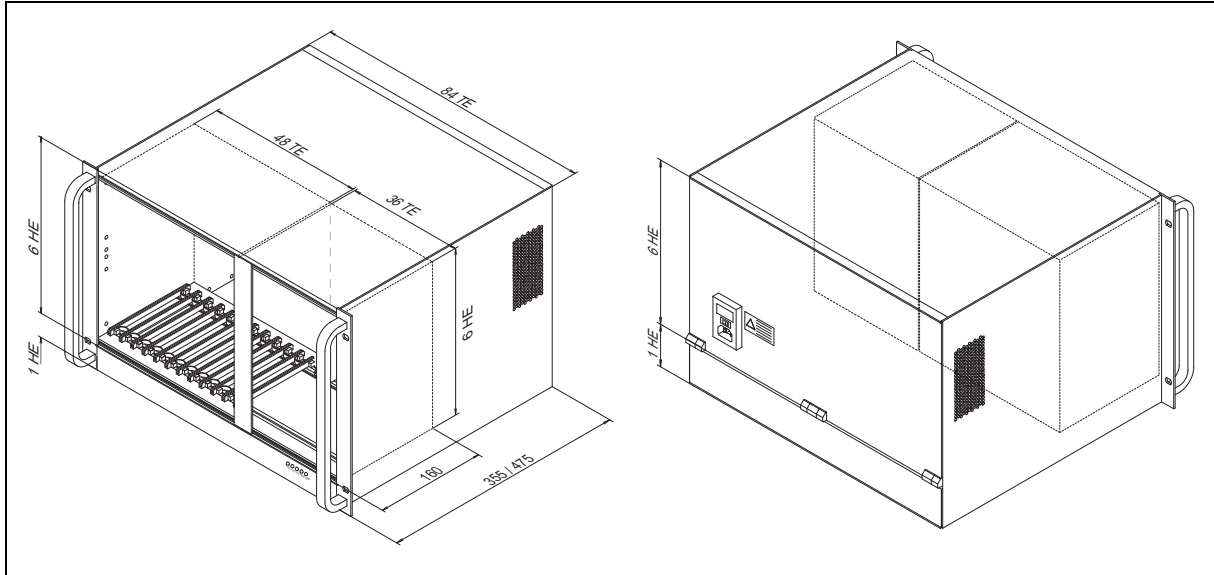

10006825



$1 HE = 1 U$
 $1 TE = 1 HP$

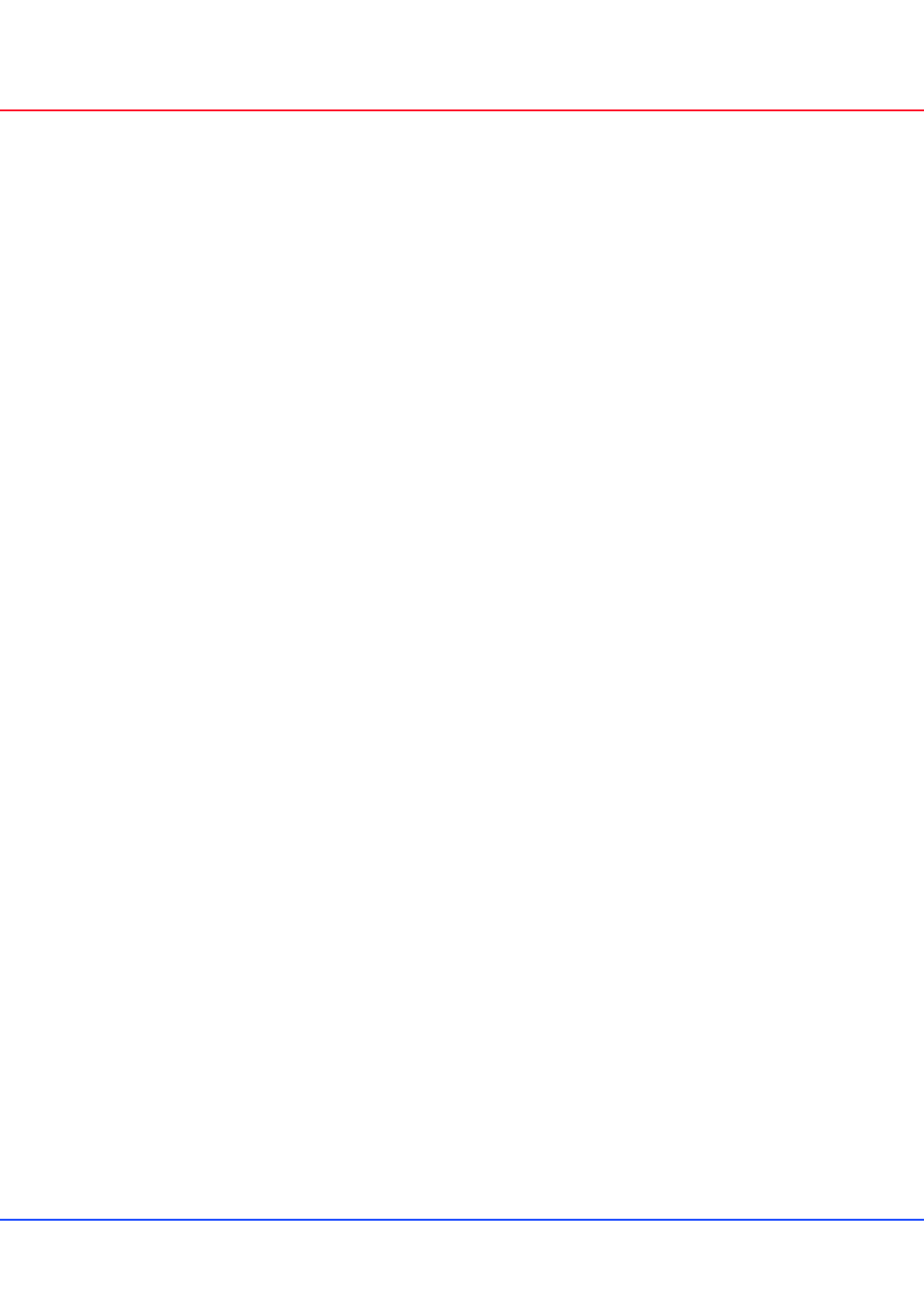

SCHROFF GMBH

**Langenalberstr. 96-100
D-75334 Straubenhardt**

www.schroff.biz

Tel.: + 49 (0) 7082 794-0

Fax: +49 (0) 7082 794-200